

Small Package Bins

Accumulate small packages for destination determination.

Designed to integrate into sorter conveyor systems and efficiently hold accumulated small packages as they flow from gravity chutes. Available in 12-way, 18-way, 24-way or 30-way bin structures, with optional rectangular or circular configuration, to align with the needs of the operation.

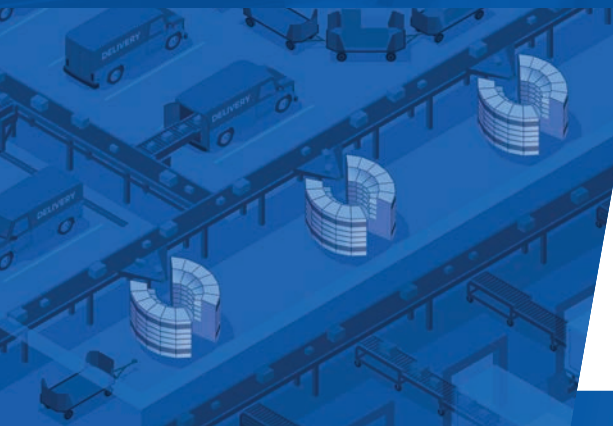

AIRCRAFT LOAD/UNLOAD
FREIGHT TRANSFER
CONVEYING OPERATIONS
ULD/PALLET MANEUVERABILITY

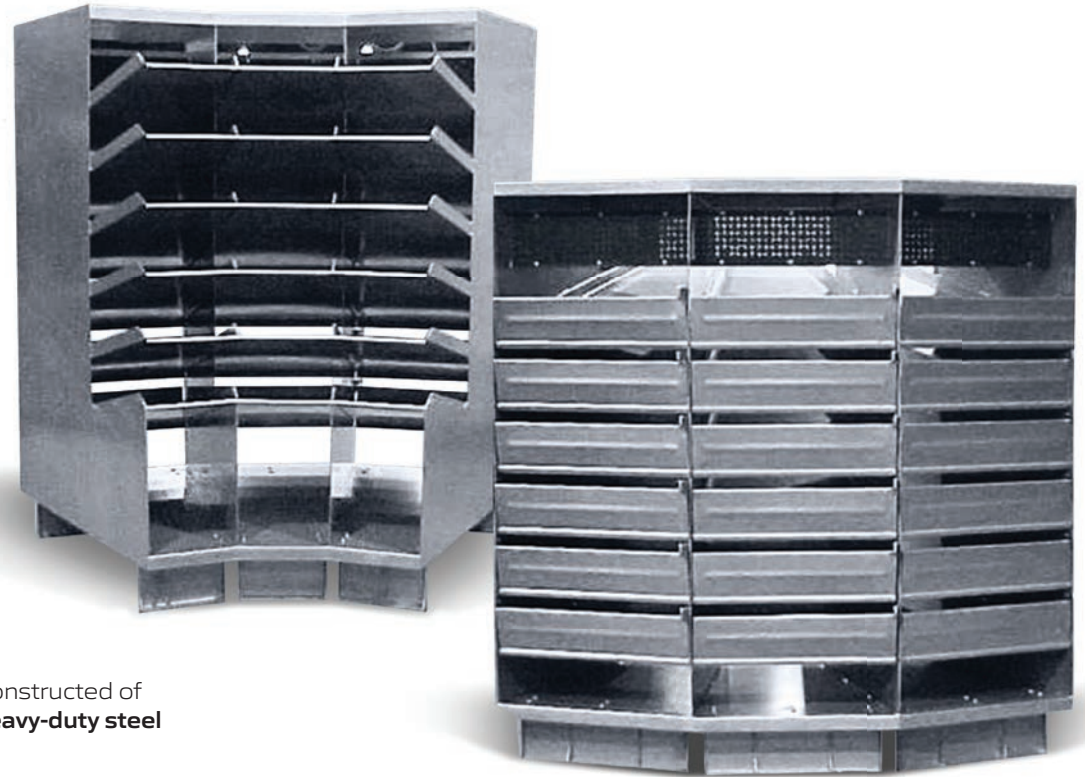

Constructed of
heavy-duty steel

Available in **12-way, 18-way,
24-way or 30-way** bin structures

Options

- Optional **rectangular or circular** configuration
- Models available with **heavy-duty casters** for more frequent maneuverability

SPECIFICATIONS

Bin Structure 12, 18, 24, 30 -Way

Dimensions w: 75.2 to 78.1 in.
d: 48 in.
h: 84.5 to 87.4 in.

Configuration Rectangular or Circular

Construction Galvanized Steel

Circular

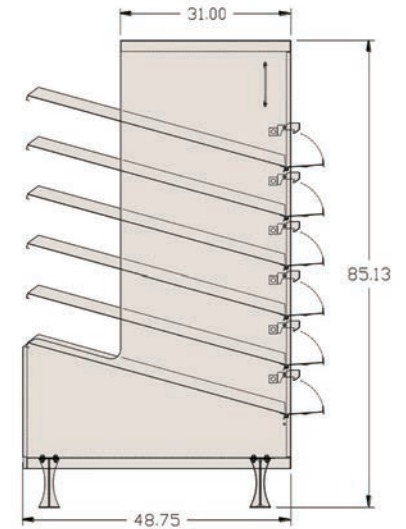
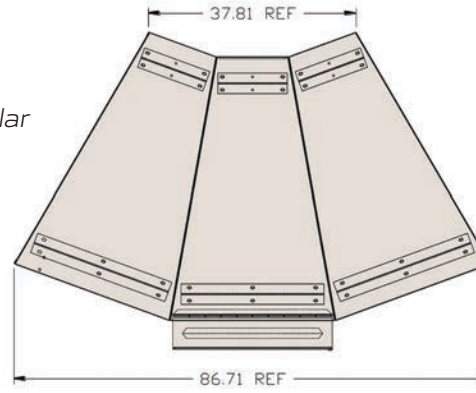

Rectangular

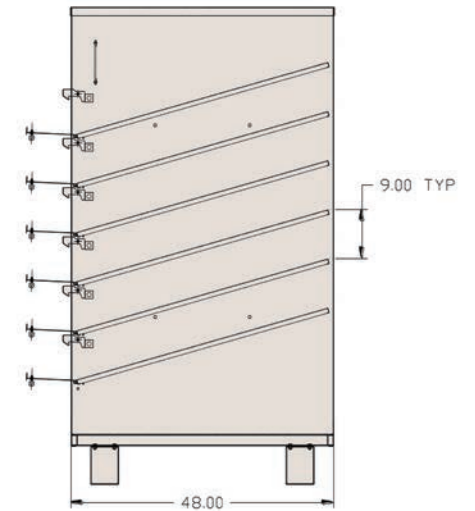
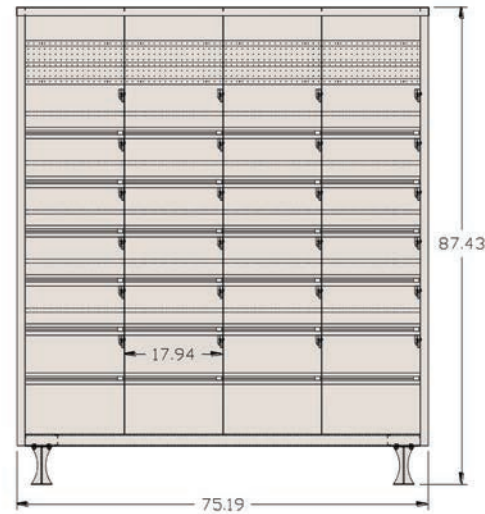

AIRCRAFT LOAD/UNLOAD
FREIGHT TRANSFER
CONVEYING OPERATIONS
ULD/PALLET MANEUVERABILITY

A world leader in airline, air cargo and material handling equipment for over 40 years, FAST Global Solutions designs, builds, installs and services an expansive portfolio of robust, ruggedly-built, dependable equipment for today's global commerce operations.

To learn more, contact the knowledgeable and experienced FAST Team:

conveyorsales@fastsolutions.com +1 (320) 634-5126 fastsolutions.com