

Door Transition Rollers

Increase transfer rates between trucks and conveying operations.

Designed to assist with the loading and unloading of delivery trucks, covering the gap between door or truck and transport conveyor. Can be mounted on T-rails adjacent to the conveyor to allow the unit to traverse to several different stations. Stores in upright position to allow movement on platform.

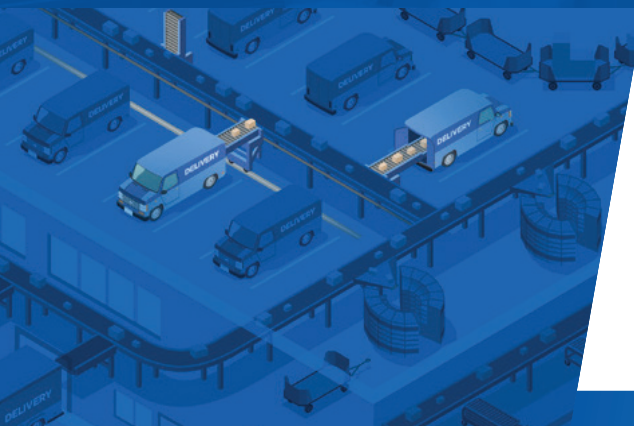

Manual **boom extension** provides appropriate length of roller conveyor surface to speed up load and unload

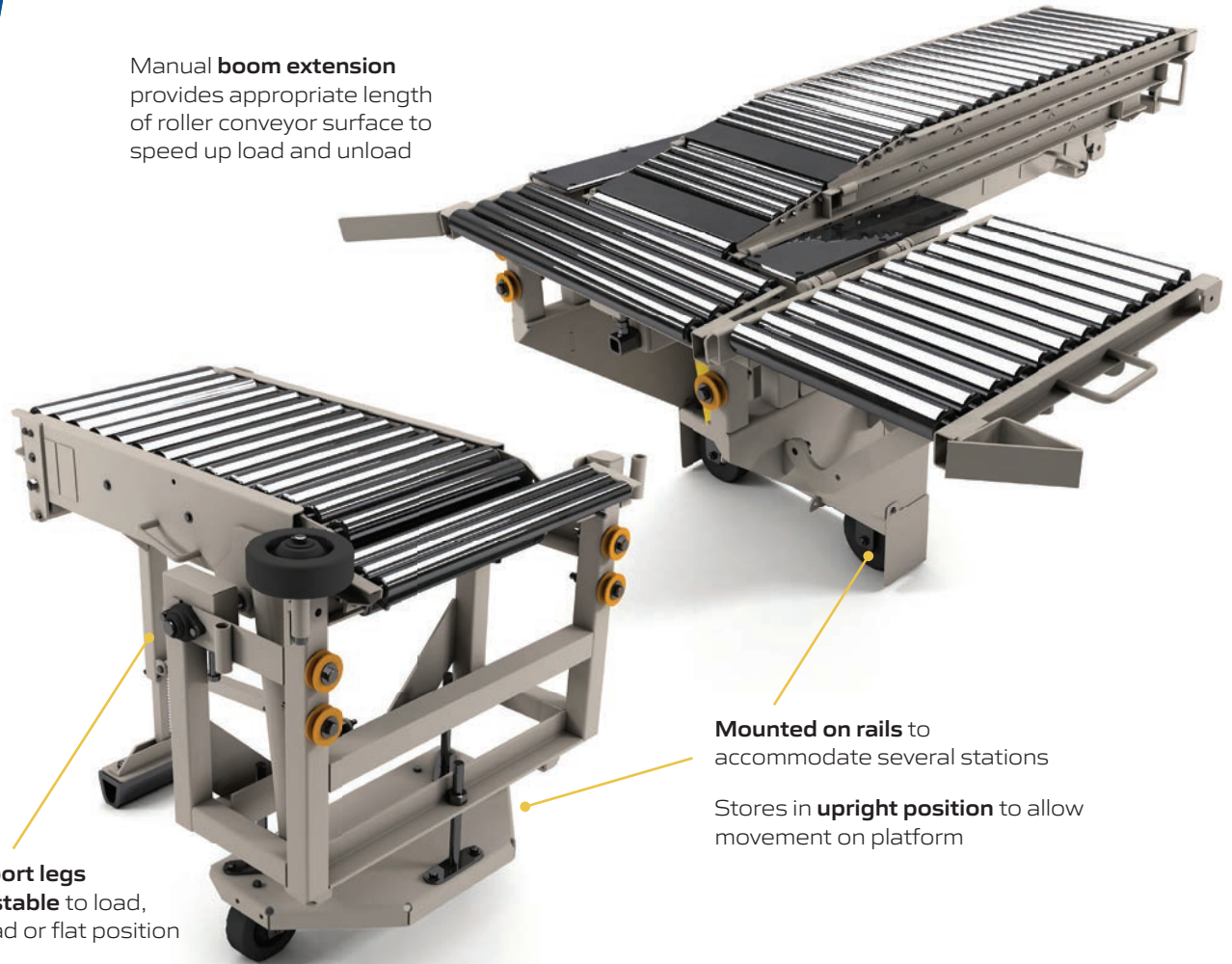

Support legs adjustable to load, unload or flat position

Mounted on rails to accommodate several stations

Stores in **upright position** to allow movement on platform

SPECIFICATIONS

Retractable Length	42.5 to 76.8 in.
Extendable Length	61.0 to 168.0 in.
Width	33.0 in.
Load Capacity	50 lbs/ft.
Rollers	1.94 in. diameter; PVC
Operation	Manual Boom Extension

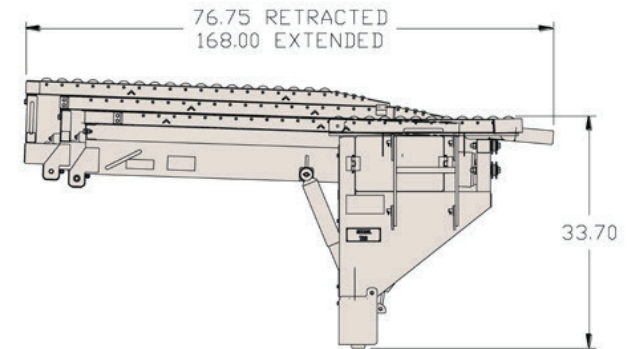
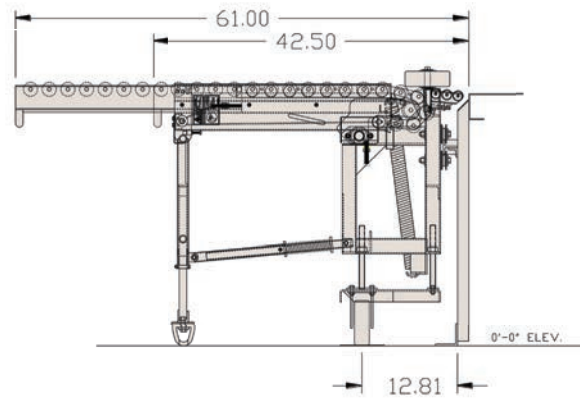
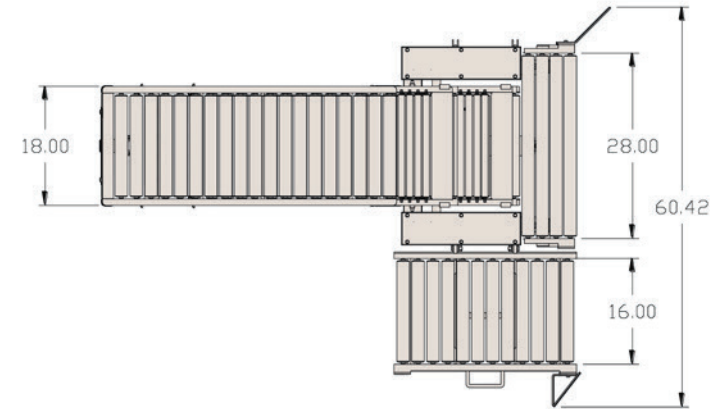
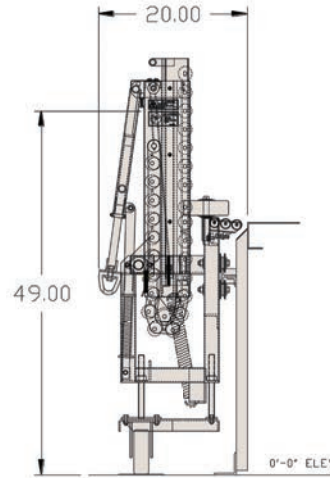

AIRCRAFT LOAD/UNLOAD
 FREIGHT TRANSFER
 CONVEYING OPERATIONS
 ULD/PALLET MANEUVERABILITY

A world leader in airline, air cargo and material handling equipment for over 40 years, FAST Global Solutions designs, builds, installs and services an expansive portfolio of robust, ruggedly-built, dependable equipment for today's global commerce operations.

To learn more, contact the knowledgeable and experienced FAST Team:

conveyorsales@fastsolutions.com +1 (320) 634-5126 fastsolutions.com